

# Powermec

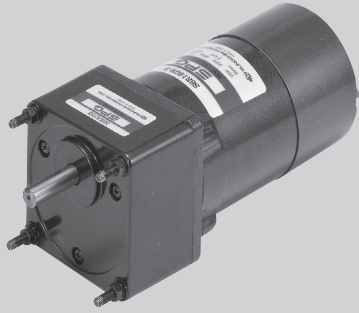

# 15W

ELECTROMAGNETIC BRAKE MOTOR

□ 80mm LEAD WIRE TYPE

SIZE mm sq.	Type	Poles	Output (W)	Voltage (V)	Frequency (Hz)	Duty	Rated Load				Starting Torque		Capacitor (uF)
							Current (A)	Speed (rpm)	Torque (kg-cm) (N-m)		(kg-cm)	(N-m)	
80	S8R15GA-E S8R15GA-E(TP) S8R15GA-ECE	4	15	1 ∅ 110	60	30min.	0.44	1550	1.00	0.100	1.50	0.150	6.0
	S8R15GB-E S8R15GB-E(TP) S8R15GB-ECE	4	15	1 ∅ 220	60	30min.	0.25	1600	1.00	0.100	1.50	0.150	1.5
	S8R15GC-E S8R15GC-E(TP) S8R15GC-ECE	4	15	1 ∅ 100	50	30min.	0.50	1200	1.30	0.130	1.25	0.125	6.0
				60	0.43		1500	1.10	0.110				
	S8R15GD-E S8R15GD-E(TP) S8R15GD-ECE	4	15	1 ∅ 200	50	30min.	0.28	1250	1.30	0.130	1.25	0.125	1.5
				60	0.24		1550	1.00	0.100				
	S8R15GE-E S8R15GE-ECE	4	15	1 ∅ 100	50	30min.	0.48	1300	1.30	0.130	1.25	0.125	6.0
				60	0.39		1600	1.10	0.110				
				1 ∅ 115	60		0.45	1600	1.00	0.100			
	S8R15GX-E S8R15GX-ECE	4	15	1 ∅ 220	50	30min.	0.16	1200	1.30	0.130	1.25	0.125	1.0
				1 ∅ 240	0.17		1.40		0.140	1.45	0.145		

- ❖ S8R15GE-E is UL approved(UL FILE NO. E172720) thermally protected type.
- ❖ Appropriate capacitors shall be used according to the voltage for S8R15GE-E type since the size of the capacitor differs by different voltages. Malfunction may occur when not used properly. Capacitor for 115V will be delivered otherwise the required voltage is informed.
- ❖ CE marked at the end of model name indicates that it is thermally protected type which has received CE. S8R15GE-ECE is available only for 115V specification.
- ❖ TP marked at the end of the model name indicates that it is standard motor with Thermal Protector mounted.  
S8R15GE-E, S8R15GX-E is thermally protected type with TP mounted.
- ❖ Above data is measured with brake removed from electromagnetic brake motor.
- ❖ "L" or "H" type does not apply to motors under 40W.

## 50Hz

GEAR RATIO	3	3.6	5	6	7.5	9	10	12.5	15	18	20	25	30	36	40	50	60	75	90	100	120	150	180	200	
	MODEL	rpm	500	416	300	250	200	166	150	120	100	83	75	60	50	41	37	30	25	20	16	15	12	10	8
S8KA□B	kg-cm	3.4	4.1	5.7	6.8	8.5	10.2	11.3	14.2	17.0	20.4	20.4	25.6	30.7	36.8	40.9	46.2	55.4	69.2	80	80	80	80	80	80
	N-m	0.333	0.402	0.559	0.666	0.833	1.000	1.107	1.392	1.666	1.999	1.999	2.509	3.009	3.606	4.008	4.530	5.433	6.786	7.840	7.840	7.840	7.840	7.840	7.840

## 60Hz

GEAR RATIO	3	3.6	5	6	7.5	9	10	12.5	15	18	20	25	30	36	40	50	60	75	90	100	120	150	180	200	
	MODEL	rpm	600	500	360	300	240	200	180	144	120	100	90	72	60	50	45	36	30	24	20	18	15	12	10
S8KA□B	kg-cm	2.9	3.5	4.9	5.8	7.3	8.7	9.7	12.2	14.6	17.5	17.5	21.9	26.3	31.5	35.0	39.6	47.5	59.4	71.3	79.2	80	80	80	80
	N-m	0.284	0.343	0.481	0.568	0.715	0.853	0.951	1.196	1.432	1.715	1.715	2.146	2.577	3.087	3.430	3.881	4.658	5.825	6.992	7.767	7.840	7.840	7.840	7.840

- ❖ The code in □ of gearhead model is for gear ratio.
- ❖ It is the permissible torque of the assembled motor and gearhead.
- ❖ The permissible torque of the motor and inter-decimal gearhead is 80 kg-cm.
- ❖ ■ color indicates that the output shaft of the geared motor rotates in the same direction as the output shaft of the motor. Others indicate rotation in the opposite direction.
- ❖ Rpm is based on synchronous speed (50Hz: 1500rpm, 60Hz: 1800rpm) divided by gear ratio.  
The actual rotation speed can be 2~20% less than displayed value depending on the load.
- ❖ "L" or "H" type does not apply to motors under 40W.

# DIMENSIONS

## GEARED MOTOR

- \* MOTOR MODEL : S8R15G□-E
- \* HEAD MODEL : S8□A3□~S8□A200□

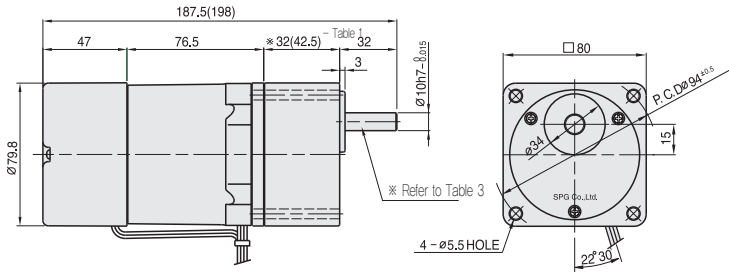

## INTER-DECIMAL GEAR HEAD

- \* MODEL : S8GX10B

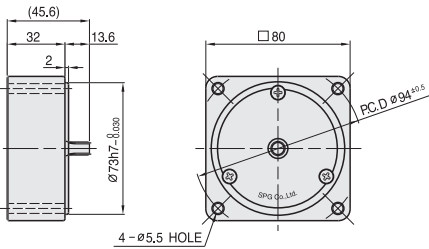

## MOTOR

- \* MOTOR MODEL : S8R15□□-E

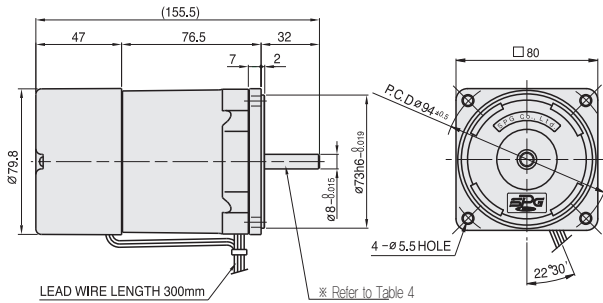

## SPEC for output shaft of gearhead - (Table3)

MODEL	TYPES OF OUTPUT SHAFT
STRAIGHT TYPE	
S8SA3□ ~S8SA200□	
D-CUT TYPE	
S8DA3□ ~S8DA200□	
KEY TYPE	
S8KA3□ ~S8KA200□	

## \* 26(35) - (Table1)

GEAR RATIO	SIZE(mm)
S8□A3□ ~ S8□A18□	32
S8□A20□ ~ S8□A200□	42.5

## WEIGHT - (Table2)

PART	WEIGHT(kg)	
MOTOR	1.86	
DECIMAL GEAR HEAD	0.43	
GEAR HEAD	S8□A3□ ~S8□A18□	0.43
	S8□A20□ ~S8□A40□	0.57
	S8□A50□ ~S8□A250□	0.61

## KEY SPEC

GEAR HEAD	MOTOR

## SPEC for output shaft of motor - (Table4)

MODEL	TYPES OF OUTPUT SHAFT
GEAR TYPE	
S8R15G□-E	
STRAIGHT TYPE	
S8R15S□-E	
D-CUT TYPE	
S8R15S□-E	
KEY TYPE	
S8R15K□-E	

# SCHEMATIC DIAGRAMS

The direction of motor rotation is as viewed from the front shaft end of the motor.

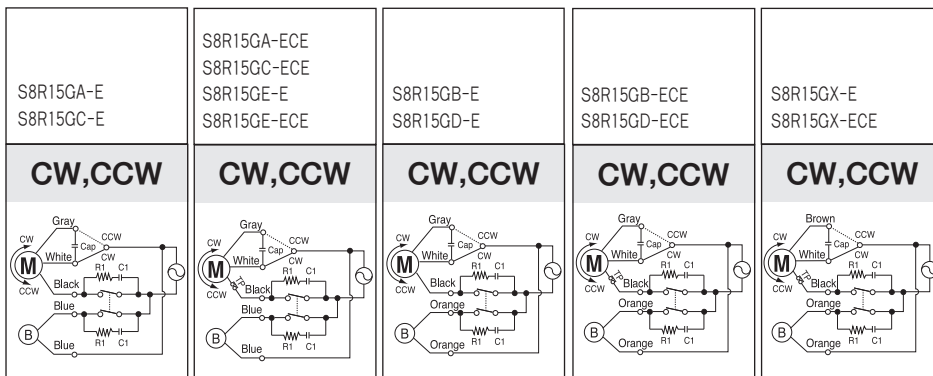

R1 = 10 ~ 200 Ω (Min. 1/4W)

C1 = 0.1 ~ 0.33 μF (AC125WV or AC250WV)