

# Powermec

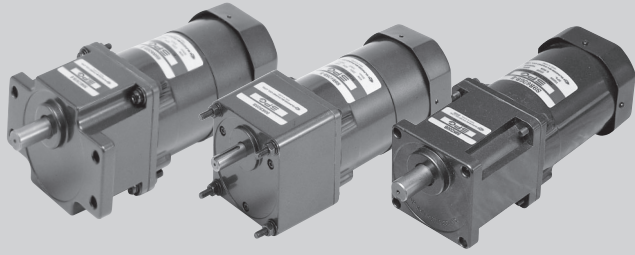

# 60W

## ELECTROMAGNETIC BRAKE MOTOR

□ 90mm LEAD WIRE TYPE

SIZE mm sq.	Type	Poles	Output (W)	Voltage (V)	Frequency (Hz)	Duty	Rated Load				Starting Torque (kg-cm)	Torque (N-m)	Capacitor (uF)		
							Current (A)	Speed (rpm)	Torque (kg-cm) (N-m)						
90	S9R60GA( )-E S9R60GA( )-E(TP) S9R60GA( )-ECE	4	60	1 ∅ 110	60	30min.	1.70	1550	3.90	0.390	7.00	0.700	25.0		
	S9R60GB( )-E S9R60GB( )-E(TP) S9R60GB( )-ECE	4	60	1 ∅ 220	60	30min.	0.90	1550	3.90	0.390	7.00	0.700	6.5		
	S9R60GC( )-E S9R60GC( )-E(TP) S9R60GC( )-ECE	4	60	1 ∅ 100	50 60	30min.	1.50 1.75	1250 1500	4.80 4.00	0.480 0.400	6.20	0.620	25.0		
	S9R60GD( )-E S9R60GD( )-E(TP) S9R60GD( )-ECE	4	60	1 ∅ 200	50 60	30min.	0.75 0.90	1250 1500	4.80 4.00	0.480 0.400	6.20	0.620	6.5		
	S9R60GE( )-E S9R60GE( )-ECE	4	60	1 ∅ 100 1 ∅ 115	50 60 60	30min.	1.30 1.70 1.40	1300 1550 1600	4.80 4.00 3.90	0.480 0.400 0.390	5.80	0.580	25.0 20.0		
	S9R60GX( )-E S9R60GX( )-ECE	4	60	1 ∅ 220 1 ∅ 240	50	30min.	0.58 0.61	1300	4.60 4.90	0.460 0.490	6.00 7.00	0.600 0.700	5.0		
	S9I60GU( )-E S9I60GU( )-ECE	4	60	3 ∅ 200	50 60	Cont.	0.60 0.50	1300 1550	4.60 3.90	0.460 0.390	9.30 8.00	0.930 0.800	—		
	S9I60GT( )-E S9I60GT( )-ECE	4	60	3 ∅ 220	50 60	Cont.	0.80 0.57	1350 1600	4.40 3.90	0.440 0.390	11.35 9.30	1.135 0.930	—		
	S9I60GS( )-E S9I60GS( )-ECE	4	60	3 ∅ 380	50	Cont.	0.27	1300	4.60	0.460	8.25	0.825	—		
					60		0.24	1550	3.90	0.390	6.50	0.650			
					3 ∅ 400	50	Cont.	0.29	1300	4.70	0.470	9.30		0.930	—
						60		0.25	1550	4.00	0.400	7.35		0.735	
					3 ∅ 415	50	Cont.	0.27	1350	4.60	0.460	9.95		0.995	—
						60		0.23	1600	3.80	0.380	7.50		0.750	
					3 ∅ 440	50	Cont.	0.31	1350	4.70	0.470	10.75		1.075	—
						60		0.25	1600	3.90	0.390	8.40		0.840	

- ❖ S9R60GE-E is UL approved (UL FILE NO. E172720) thermally protected type.
- ❖ Appropriate capacitors shall be used according to the voltage for S9R60GE-E type since the size of the capacitor differs by different voltages. Malfunction may occur when not used properly. Capacitor for 115V will be delivered otherwise the required voltage is informed.
- ❖ CE marked at the end of model name indicates that it is thermally protected type which has received CE with built-in TP.  
S9R60GE( )-ECE is available only for 115V specification.
- ❖ TP marked at the end of the model name indicates that it is standard motor with Thermal Protector mounted.  
S9R60GE-E, S9R60GX-E is thermally protected type with TP mounted.
- ❖ Above data is measured with brake removed from electromagnetic brake motor.
- ❖ ( ) is for marking 'L' type or 'H'. 'L' should be used with gearhead 'L' and 'H' should be used with gearhead 'H'.
- ❖ For a three-phase 380V~440V motor, be cautious when using the inverter. When inverter is used, the insulation of winding becomes hot and may cause damage to motor.

## 50Hz

MODEL	GEAR RATIO	3	3.6	5	6	7.5	9	10	12.5	15	18	20	25	30	36	40	50	60	75	90	100	120	150	180	200
	rpm	500	416	300	250	200	166	150	120	100	83	75	60	50	41	37	30	25	20	16	15	12	10	8	7.5
S9KC□( )	kg-cm	12.2	14.6	20.3	24.3	30.4	36.5	40.5	45.6	54.8	65.7	73.0	82.5	99.0	119	132	165	198	200	200	200	200	200	200	200
S9KC□( )-S	N-m	1.196	1.431	1.989	2.381	2.989	3.577	3.969	4.469	5.370	6.439	7.154	8.085	9.702	11.66	12.94	16.17	19.40	19.60	19.60	19.60	19.60	19.60	19.60	19.60

## 60Hz

MODEL	GEAR RATIO	3	3.6	5	6	7.5	9	10	12.5	15	18	20	25	30	36	40	50	60	75	90	100	120	150	180	200
	rpm	600	500	360	300	240	200	180	144	120	100	90	72	60	50	45	36	30	24	20	18	15	12	10	9
S9KC□( )	kg-cm	9.72	11.7	16.2	19.4	24.3	29.2	32.4	36.5	43.8	52.6	58.4	66.0	79.2	95.0	106	132	158	177	200	200	200	200	200	200
S9KC□( )-S	N-m	0.953	1.147	1.588	1.901	2.381	2.862	3.175	3.577	4.292	5.155	5.723	6.468	7.762	9.310	10.39	12.94	15.48	17.35	19.60	19.60	19.60	19.60	19.60	19.60

- ❖ The code in □ of gearhead model is for gear ratio.
- ❖ It is the permissible torque of the assembled motor and gearhead.
- ❖ The permissible torque of the motor and inter-decimal gearhead is 200 kg-cm.
- ❖ ■ color indicates that the output shaft of the geared motor rotates in the same direction as the output shaft of the motor. Others indicate rotation in the opposite direction.
- ❖ Rpm is based on synchronous speed (50Hz: 1500rpm, 60Hz: 1800rpm) divided by gear ratio.  
The actual rotation speed can be 2~20% less than displayed value depending on the load.
- ❖ ( ) is for marking 'L' type or 'H'. 'L' should be used with motor 'L' and 'H' should be used with motor 'H'.

# DIMENSIONS

## + GEARED MOTOR

\* MOTOR MODEL : S9R60G□□-E  
 \* HEAD MODEL : S9□C3B□-S~S9□C200B□-S

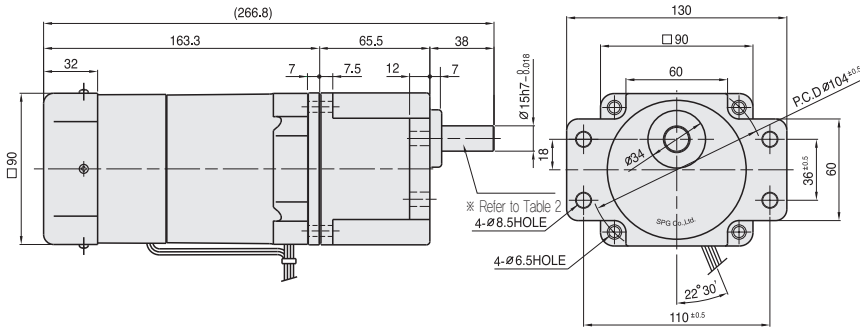

\* HEAD MODEL : S9□C3B□-S~S9□C200B□

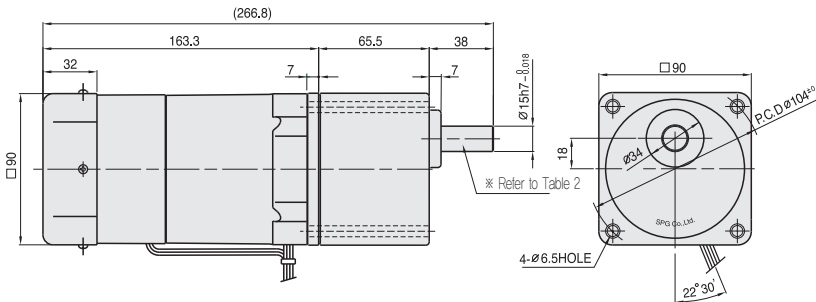

## + MOTOR

\* MOTOR MODEL : S9R60□□□-E

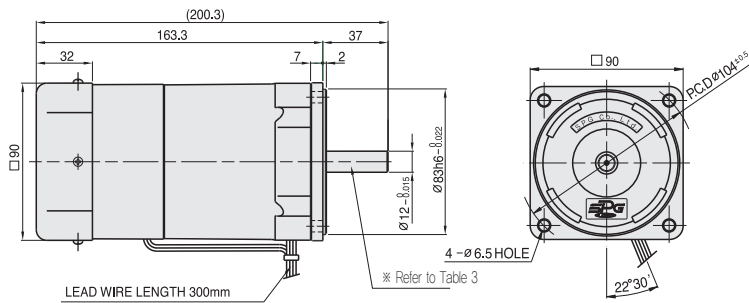

## + INTER-DECIMAL GEAR HEAD

\* MODEL : S9GX10B(H,L)-S

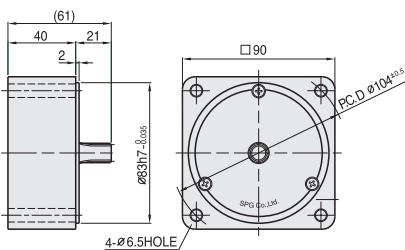

## + WEIGHT - (Table1)

PART	WEIGHT(kg)	
MOTOR	2.90	
DECIMAL GEAR HEAD	0.65	
GEAR HEAD	S9□C3B□ ~S9□C10B□	1.21
	S9□C12.5B□ ~S9□C20B□	1.30
	S9□C25B□ ~S9□C60B□	1.40
	S9□C75B□ ~S9□C200B□	1.45

## + KEY SPEC

GEAR HEAD	MOTOR

## + SPEC for output shaft of gearhead - (Table2)

MODEL	TYPES OF OUTPUT SHAFT
STRAIGHT TYPE	
S9SC3B□ ~S9SC200B□	
D-CUT TYPE	
S9DC3B□ ~S9DC200B□	
KEY TYPE	
S9KC3B□ ~S9KC200B□	

## + SPEC for output shaft of motor - (Table3)

MODEL	TYPES OF OUTPUT SHAFT
GEAR TYPE	
S9R60G□□-E	
STRAIGHT TYPE	
S9R60S□-E	
D-CUT TYPE	
S9R60D□-E	
KEY TYPE	
S9R60K□-E	

# DIMENSIONS

## + GEARED MOTOR

※ MOTOR MODEL : S9R60□H-E  
 ※ HEAD MODEL □ : S9□D3B~S9□D200B

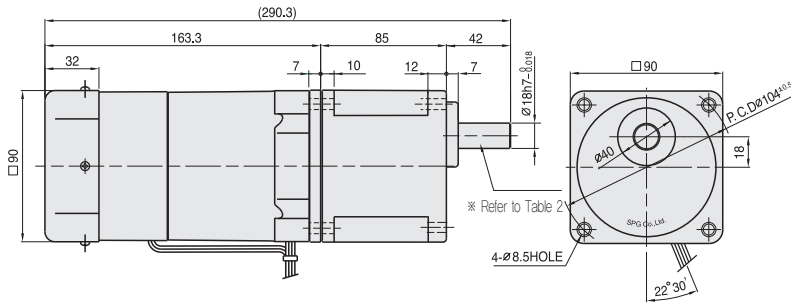

## + WEIGHT - (Table 1)

PART		WEIGHT(kg)
MOTOR		2,90
GEAR HEAD	S9□D3B ~S9□D10B	1,65
	S9□D12.5B ~S9□D20B	1,80
	S9□D25B ~S9□D60B	1,90
	S9□D75B ~S9□D200B	1,95

## + KEY SPEC

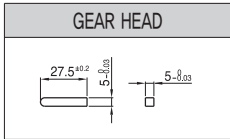

## + SPEC for output shaft of gearhead - (Table 2)

MODEL	TYPES OF OUTPUT SHAF	MODEL	TYPES OF OUTPUT SHAF	MODEL	TYPES OF OUTPUT SHAF
S9SD3B ~S9SD200B	STRAIGHT TYPE 	S9DD3B ~S9DD200B	D-CUT TYPE 	S9KD3B ~S9KD200B	KEY TYPE 

## 50Hz

GEAR RATIO	MODEL																											
	rpm	kg-cm	N·m	3	3.6	5	6	7.5	9	10	12.5	15	18	20	25	30	36	40	50	60	75	90	100	120	150	180	200	
S9KD□B				12.2	14.6	20.3	24.3	30.4	36.5	40.5	45.6	54.8	65.7	73.0	82.5	99.0	119	132	165	198	221	266	295	300	300	300	300	300
				1.196	1.431	1.989	2.381	2.989	3.577	3.969	4.469	5.370	6.439	7.154	8.085	9.702	11.66	12.94	16.17	19.40	21.67	26.09	28.93	29.42	29.42	29.42	29.42	29.42

## 60Hz

GEAR RATIO	MODEL																										
	rpm	kg-cm	cmN·m	3	3.6	5	6	7.5	9	10	12.5	15	18	20	25	30	36	40	50	60	75	90	100	120	150	180	200
S9KD□B				9.72	11.7	16.2	19.4	24.3	29.2	32.4	36.5	43.8	52.6	58.4	66.0	79.2	95.0	106	132	158	177	212	236	283	300	300	300
				0.953	1.147	1.588	1.901	2.381	2.862	3.175	3.577	4.292	5.155	5.723	6.468	7.762	9.310	10.39	12.94	15.48	17.35	20.79	23.14	27.75	29.42	29.42	29.42

- ❖ The code in □ of gearhead model is for gear ratio. ❖ It is the ambient torque of the assembled motor and gearhead.
- ❖ The permissible torque of the motor and inter-decimal gearhead is 300 kg-cm.
- ❖ ■ color indicates that the output shaft of the geared motor rotates in the same direction as the output shaft of the motor. Others indicate rotation direction in the opposite direction.
- ❖ Rpm is based on synchronous speed (50Hz: 1500rpm, 60Hz: 1800rpm) divided by gear ratio. The actual rotation speed can be 2~20% less than displayed value depending on the load.
- ❖ Only "H" type is applicable. Please use "H" type motor.

# SCHEMATIC DIAGRAMS

The direction of motor rotation is as viewed from the front shaft end of the motor.

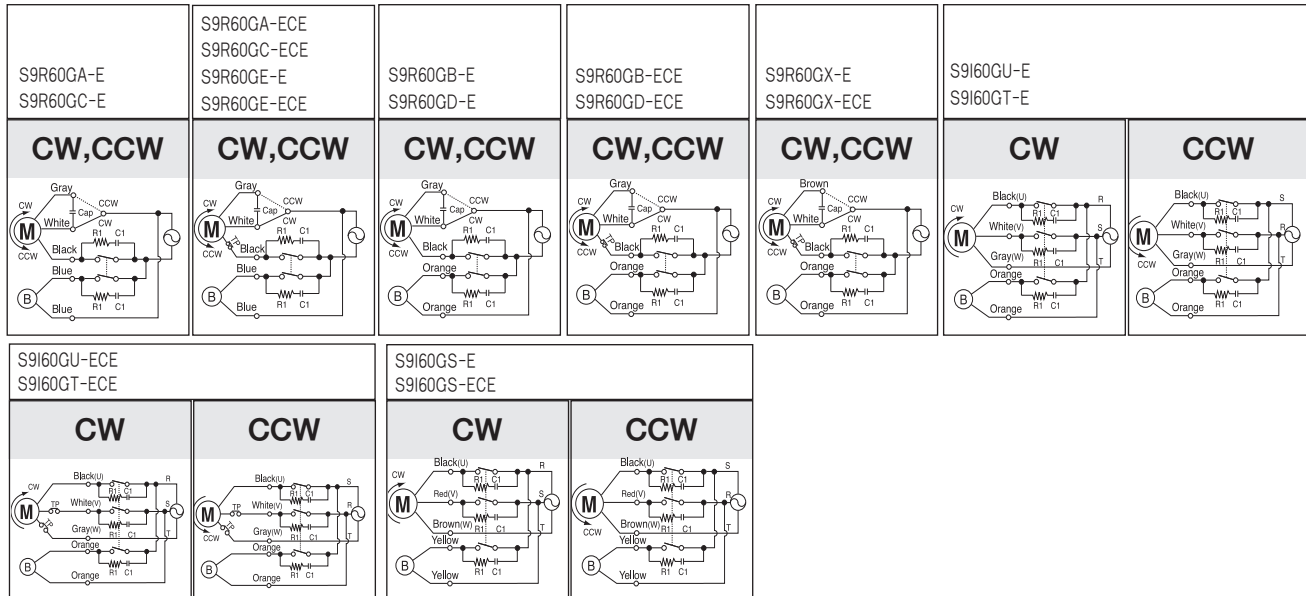

R<sub>1</sub> = 10 ~ 200 Ω (Min. 1/4W) C<sub>1</sub> = 0.1 ~ 0.33 μF (AC125WV or AC250WV)